

COM Express® basic Type 7 with Intel® XEON® D-1700 SOC processors

- Server-grade platform
- Quad 10 GbE interfaces
- High-speed connectivity 16x PCIe 4.0 + 16x PCIe 3.0, SATA, USB 3.0
- Up to 1 TByte NVMe SSD onboard
- Industrial grade versions

COMPLIANCE	COM Express® Basic, Pin-out Type 7 - COM.0 R3.1 by default, COM.0 R3.0 on request																										
DIMENSIONS	95 x 125 mm																										
CPU (SoC)	Intel® Xeon® D-1700 Processor Series For details see table "CPU variants" given below																										
CHIPSET	-																										
MAIN MEMORY	2x DDR4 SODIMM for up to 64 GByte ECC (non ECC on request) on request: 4x DDR4 SODIMM for up to 128 GByte ECC (non ECC on request)																										
ETHERNET CONTROLLER	Intel® I225LM/IT Intel® Quad 10GbE LAN integrated in SoC																										
ETHERNET	1x 1/2.5 Gb (1/2.5 GBASE-T) 4x 10GbE (10 GBASE-KR) according COM.0 R3.1																										
STORAGE	2x SATA 6Gb/s																										
FLASH ONBOARD	Up to 1 TByte NVMe SSD (on request)																										
PCI EXPRESS®	16x PCIe Gen4 (1 x16, 2 x8, 4 x4) according COM.0 R3.1 16x PCIe Gen3 (2 x8, 4 x4, 8 x2)																										
USB	4x USB 3.0 / USB 2.0																										
SERIAL	2x serial interface (RX/TX only)																										
OTHER FEATURES	SPI, LPC, SMB, Fast I ² C, Staged Watchdog, RTC																										
SPECIAL FEATURES	TPM 2.0																										
FEATURES ON REQUEST	<table border="0"> <tr> <td>4x 10G Ethernet</td> <td>PICMG COM.0 R3.0 compliance</td> </tr> <tr> <td>4x 10G Ethernet-LEK</td> <td>Configurations for:</td> </tr> <tr> <td></td> <td>SFI native: LEK 1.0-4ports (COM.0 R3.0)</td> </tr> <tr> <td></td> <td>10GBASE-T: LEK 2.1-4ports (COM.0 R3.0)</td> </tr> <tr> <td></td> <td>CEI: LEK 7.0-4ports (COM.0 R3.1)</td> </tr> <tr> <td>PCI Express® COMe #16-31</td> <td>PICMG COM.0 R3.0 compliance</td> </tr> <tr> <td>PCI Express® COMe #0-7</td> <td>Enable PCIe x1 lanes on COMe PCIe #1, #3, #5</td> </tr> <tr> <td>NVMe SSD</td> <td>Up to 1 TByte NVMe PCIe SSD NAND Flash</td> </tr> <tr> <td>2nd SPI Flash</td> <td>On-module fail-safe 2nd SPI flash implemented for additional safety</td> </tr> <tr> <td>SODIMM sockets</td> <td>4x SODIMM sockets (2x on top side + 2x on bottom side)</td> </tr> <tr> <td>SODIMMs</td> <td>Non-ECC SODIMMs</td> </tr> <tr> <td>CPU</td> <td>other CPUs than offered as standard versions</td> </tr> <tr> <td>BIOS</td> <td>custom BIOS configurations</td> </tr> </table>	4x 10G Ethernet	PICMG COM.0 R3.0 compliance	4x 10G Ethernet-LEK	Configurations for:		SFI native: LEK 1.0-4ports (COM.0 R3.0)		10GBASE-T: LEK 2.1-4ports (COM.0 R3.0)		CEI: LEK 7.0-4ports (COM.0 R3.1)	PCI Express® COMe #16-31	PICMG COM.0 R3.0 compliance	PCI Express® COMe #0-7	Enable PCIe x1 lanes on COMe PCIe #1, #3, #5	NVMe SSD	Up to 1 TByte NVMe PCIe SSD NAND Flash	2nd SPI Flash	On-module fail-safe 2nd SPI flash implemented for additional safety	SODIMM sockets	4x SODIMM sockets (2x on top side + 2x on bottom side)	SODIMMs	Non-ECC SODIMMs	CPU	other CPUs than offered as standard versions	BIOS	custom BIOS configurations
4x 10G Ethernet	PICMG COM.0 R3.0 compliance																										
4x 10G Ethernet-LEK	Configurations for:																										
	SFI native: LEK 1.0-4ports (COM.0 R3.0)																										
	10GBASE-T: LEK 2.1-4ports (COM.0 R3.0)																										
	CEI: LEK 7.0-4ports (COM.0 R3.1)																										
PCI Express® COMe #16-31	PICMG COM.0 R3.0 compliance																										
PCI Express® COMe #0-7	Enable PCIe x1 lanes on COMe PCIe #1, #3, #5																										
NVMe SSD	Up to 1 TByte NVMe PCIe SSD NAND Flash																										
2nd SPI Flash	On-module fail-safe 2nd SPI flash implemented for additional safety																										
SODIMM sockets	4x SODIMM sockets (2x on top side + 2x on bottom side)																										
SODIMMs	Non-ECC SODIMMs																										
CPU	other CPUs than offered as standard versions																										
BIOS	custom BIOS configurations																										
POWER MANAGEMENT	ACPI 6.0																										
POWER SUPPLY	8.5 V – 20 V Wide Range, Single Supply Power																										
BIOS	AMI UEFI																										
OPERATING SYSTEM	Linux, Windows 10 IoT Enterprise, Windows Server 2022																										
TEMPERATURE	Commercial temperature: 0 °C to +60 °C operating, -30 °C to +85 °C non-operating Industrial temperature: -40 °C to +85 °C operating, -40 °C to +85 °C non-operating																										
HUMIDITY	93 % relative Humidity at 40 °C, non-condensing (according to IEC 60068-2-78)																										
SUPPORTED MODULES	COMe-bID7 xxxxx commercial grade COMe-bID7 E2 xxxxx industrial grade																										

PROCESSOR NUMBER	STD FOR COME-bID7	TDP (W)	CORES	EXTEND TEMP	CACHE (MByte)	BASE FREQ (GHz)	ALL/MAX TURBO (GHz)	MEM-FREQ (MT/S)	QUAD-LAN	QAT MODE
D-1746TER	yes	67/56	10	yes	15	2.0	2.5/3.1	2667	yes	no
D-1749NT	yes	90	10	no	15	3.0	3.5/3.5	2667	yes	yes
D-1748TE	on request	65	10	yes	15	2.3	2.8/3.4	2400	yes	no
D-1747NTE	yes	80	10	yes	15	2.5	3.0/3.5	2933	yes	yes
D-1735TR	yes	59	8	no	15	2.2	2.7/3.4	2933	yes	no
D-1732TE	yes	52	8	yes	15	1.9	2.4/3.0	2667	yes	no
D-1734NT	on request	50	8	no	15	2.0	2.5/3.1	2667	yes	yes
D-1736NT	on request	67	8	no	15	2.7	3.2/3.5	2667	yes	yes
D-1733NT	on request	53	8	no	15	2.0	2.5/3.1	2400	yes	yes
D-1715TER	yes	50	4	yes	10	2.4	2.9/3.5	2667	yes	no
D-1712TR	yes	40	4	no	10	2.0	2.5/3.1	2400	yes	no
D-1718T	on request	46	4	no	10	2.6	3.1/3.5	2933	yes	no
D-1713NT	on request	45	4	no	10	2.2	2.9/3.5	2400	yes	yes
D-1713NTE	on request	45	4	yes	10	2.2	2.7/3.3	2400	yes	yes
D-1739	on request	83	8	no	10	3.0	3.5/3.5	2933	no	no
D-1736	on request	55	8	no	10	2.3	2.8/3.4	2933	no	no
D-1726	on request	70	6	no	10	2.9	3.4/3.5	2933	no	no
D-1722NE	on request	36	6	yes	10	1.7	2.1/2.7	2400	no	no
D-1714	on request	38	4	no	10	2.3	2.8/3.4	2667	no	no
D-1702	on request	25	2	no	10	1.6	1.7/1.7	2400	no	no

Block Diagram

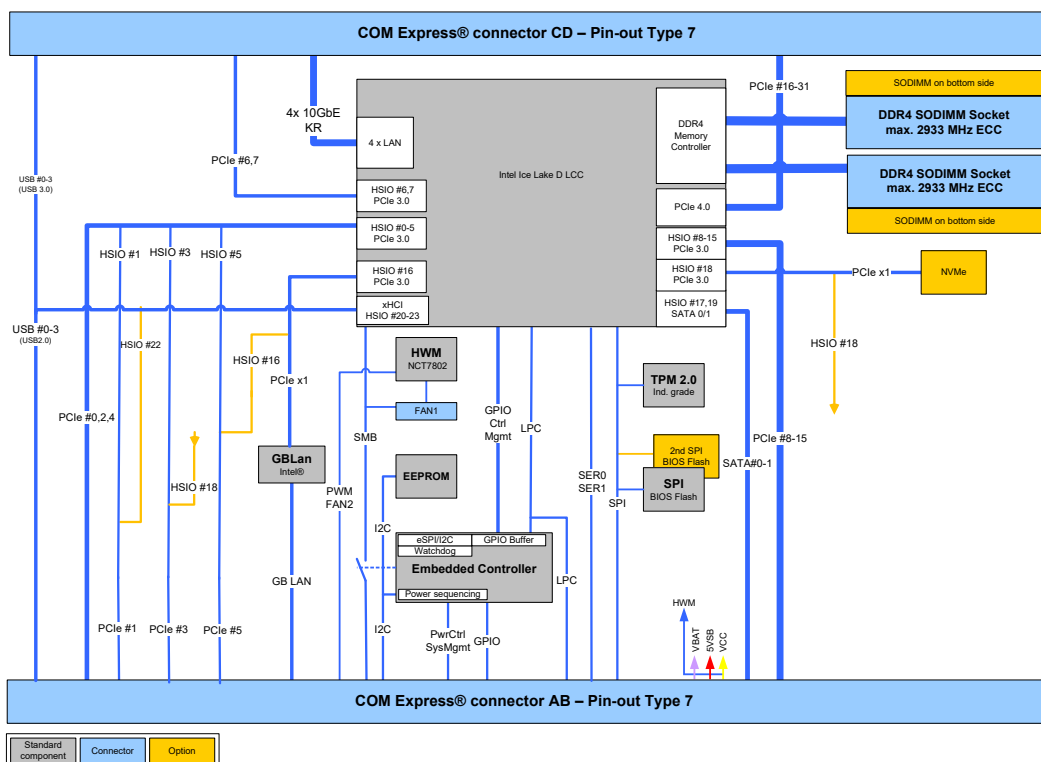

PART NO.	COM.0 REV	CPU	1 GbE	SOC-LAN	SOC-LEK	SO-DIMM SOCKETS	NVMe	OP. TEMPERATURE
68008-0000-12-1	3.1	D-1712TR	I225LM	4x 10GBASE	7.6	2	no	0 °C to 60 °C
68008-0000-35-1	3.1	D-1735TR	I225LM	4x 10GBASE	7.6	2	no	0 °C to +60 °C
68008-0000-49-2	3.1	D-1749NT	I225LM	4x 10GBASE	7.6	2	no	0 °C to +60 °C
68009-0000-15-1	3.1	D-1715TER	I225IT	4x 10GBASE	7.6	2	no	-40 °C to +85 °C
68009-0000-32-1	3.1	D-1732TE	I225IT	4x 10GBASE	7.6	2	no	-40 °C to +85 °C
68009-0000-46-1	3.1	D-1746TER	I225IT	4x 10GBASE	7.6	2	no	-40 °C to +85 °C
68009-0000-47-2	3.1	D-1747NTE	I225IT	4x 10GBASE	7.6	2	no	-40 °C to +85 °C

Please contact your sales representative for other CPU versions or LAN configurations
 Please contact tech support for custom UEFI firmware
 On the COMe-bID7 QAT is disabled by default - a custom UEFI firmware is required for QAT enabled

Carrier

ARTICLE	PART NO.	DESCRIPTION
COME EVAL CARRIER T7 G2	68301-0001-00-8	COM Express® Eval Carrier Type 7 G2
ADA-COME-T7-G2 4X10G RJ45 - DEV-TOOL	68301-0000-01-4	Adapter Card with 4x RJ45 ports for use with COM Express® Eval Carrier Type 7 G2 – X557 PHY
ADA-COME-T7-G2 4X10G DAC - DEV-TOOL	68301-0000-04-4	Adapter Card with 4x 10G-KR ports for use with COM Express® Eval Carrier Type 7 G2 – no PHY
ADA-COME-T7-G2 4X10G SFP+ - C827-IM1	68301-0000-05-4	Adapter Card with 4x SFP+ ports for use with COM Express® Eval Carrier Type 7 G2 – C827-IM1 PHY

Cooling

ARTICLE	PART NO.	DESCRIPTION
HSP COME-BID7 (E2) THREAD	68009-0000-99-0	Heatspreader for COMe-bID7 commercial and E2, threaded mounting holes
HSP COME-BDV7 (E2) THROUGH	68009-0000-99-1	Heatspreader for COMe-bID7 commercial and E2, through holes
HSK COME-BASIC ACTIVE (W/O HSP)	38025-0000-99-0C05	Active Cooler for COMe-bxL6/bDV7/bID7 to be mounted on HSP
HSK COME-BASIC PASSIVE (W/O HSP)	38025-0000-99-0C06	Passive Cooler for COMe-bxL6/bDV7/bID7 to be mounted on HSP

PART NO.	MIN. SPEC.	SIZE	ECC/NON-ECC	OP. TEMPERATURE
97030-0832-BID7	DDR4-3200	8 GByte	ECC	0 °C to +60 °C
97030-1632-BID7	DDR4-3200	16 GByte	ECC	0 °C to +60 °C
97030-3232-BID7	DDR4-3200	32 GByte	ECC	0 °C to +60 °C
97031-0832-BID7	DDR4-3200	8 GByte	ECC	-40 °C to +85 °C
97031-1632-BID7	DDR4-3200	16 GByte	ECC	-40 °C to +85 °C
97031-3232-BID7	DDR4-3200	32 GByte	ECC	-40 °C to +85 °C

Global Headquarters

Kontron Europe GmbH

Gutenbergstraße 2
85737 Ismaning, Germany
Tel.: + 49 821 4086-0
info@kontron.com

www.kontron.com

